



Project:

Item Number:

Quantity:

Soup and Salad Cart

Item No.	
75731	3 Pan Forced Air Cold Pan with Two Drop-in Induction Warmers/Rethermalizers



DESCRIPTION

Vollrath's Soup and Salad Cart combines a Forced Air Cold Pan with two Mirage® Drop-in Induction Warmer/Rethermalizers in a customizable Signature Server® base. Dual forced air flows across two sides for more even and consistent chilling. Induction warmers/rethermalizers run dry without a water bath, improve food quality and minimize food waste; while using a fraction of the energy.

STANDARD FEATURES

Base

- 14 gauge stainless steel corner supports
- 18 gauge stainless steel framing
- ¾" removable decor panels on all sides
- 5" swivel locking casters (2 locking)
- 8 ft. power cord

Breath Guards

- Progressive or Traditional style
- Meet requirements of NSF 2
- Extruded aluminum construction with standard baseplate mounting to countertop
- ¼" tempered glass side panels
- ¼" plexiglass end panels

Forced Air Cold Pan

- Shallow recess for prominent food display
- Seamless well is 18-gauge 300 series stainless steel
- The inner well insulated with foamed-in-place polyurethane foam insulation
- Accepts food pans up to 6" (15.2 cm) deep
- Factory set cold control on compressor provides mini-defrost with every compressor cycle
- ¾" (1.9 cm) integral drain is standard
- NSF 7 Listed
- Five year warranty on compressor

Mirage® Drop-in Induction Warmer/Rethermalizers

- Two 7 Qt. drop-ins
- 800 watt 3D induction coils heat food evenly and efficiently
- Dry use. Heat is transferred directly to the induction-ready inset, which eliminates the need to monitor and refill water levels
- Three temperature sensors have direct contact with the inset to provide very accurate temperature control
- Stir indicator LED informs operators the food should be stirred
- Temperature control in °F and °C
- Four presets - broth soups, crème soups, chili, mac and cheese
- Requires use of included Vollrath induction-ready insets
- NSF4 listed

OPTIONS

Countertop (Choose 1)

- 18 gauge 300 Series stainless steel
- Corian® solid surface
- Laminate:
Specify manufacturer and color:

Exterior Panels (Choose 1)

- Laminate panels (standard).
Specify manufacturer and color:

- Standard WCM color options (See Vollrath.com for complete list)

Toe Kicks

- Stainless steel toe kick (field assembly required)

Corner Posts

- Stainless steel finish
- Powder coated finish (Specify color)

Due to continued product improvement, please consult www.vollrath.com for current product specifications

Approvals	Date

Soup and Salad Cart

DIMENSIONS

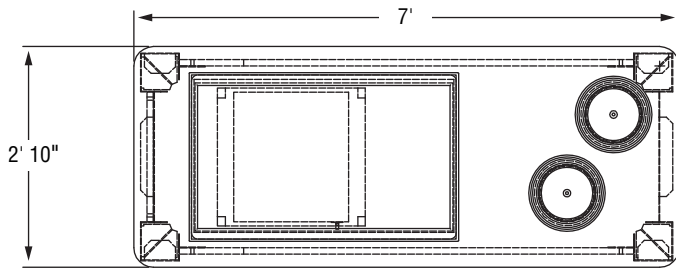

Top View

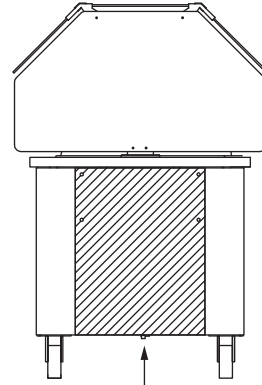

Power Supply Cord Exit

End View

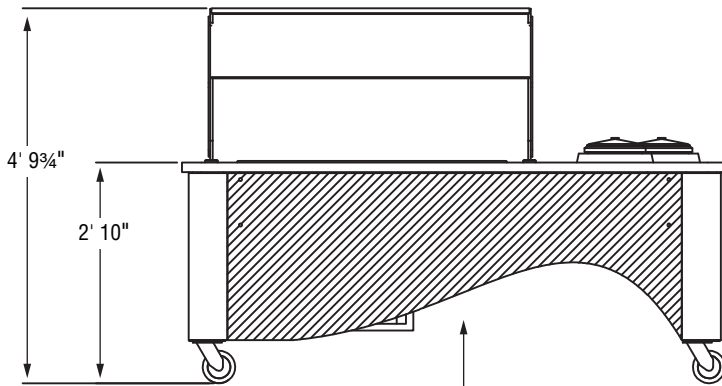

Power Supply Cord Exit

Customer Side View

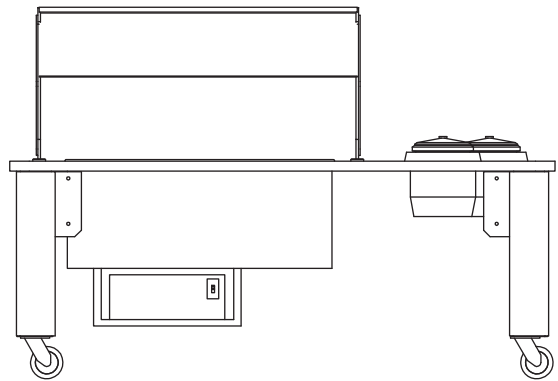

Panels Removed

SPECIFICATIONS

Item No.	Electrical		
	Volts	Amps	Plug
75731	120V	12.7	NEMA 5-20P

Receptacles

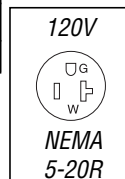

The Vollrath Company, L.L.C.
 1236 North 18th Street
 Sheboygan, WI 53081-3201 U.S.A.
 Main Tel: 800.624.2051 or 920.457.4851
 Main Fax: 800.752.5620 or 920.459.6573
 Customer Service: 800.628.0830

Technical Services
 techservicereps@vollrathco.com
 Induction Products: 800.825.6036
 Countertop Warming Products:
 800.354.1970
 All Other Products: 800.628.0832