



Project:

Item Number:

Quantity:

## FORCED-AIR COLD-PAN DROP-INS



### AGENCY LISTINGS



Units meet NSF7 performance testing for open-top, refrigerated buffet units.

### CLEARANCE AND ENVIRONMENT

- Countertop: Minimum is 30" (76.2 cm) high.
- Zero clearance is needed on all sides and 3" (7.6 cm) clearance from the condenser air inlet and outlet.
- This unit is made for indoor use only, in ambient temperatures below 86 °F (30 °C); warmer temperatures will take unit out of NSF compliance and could void the warranty.
- Requires at least 80 square inches for both fresh-air intake and exhaust. See back page for details.
- Use with adapter bars and/or templates.
- Prevent drafts and room air currents from disturbing the curtain of cold air immediately above the food pans.

### WARRANTY

All models shown come with Vollrath's standard warranty against defects in materials and workmanship with an additional four years on the compressor. For full warranty details, please refer to [vollrathfoodservice.com](http://vollrathfoodservice.com).

*Due to continued product improvement, please consult [vollrathfoodservice.com](http://vollrathfoodservice.com) for current product specifications.*

### ITEMS

Item	Description
FC-4C-03120-FA	3-Pan Forced-Air Cold Drop-in
FC-4C-04120-FA	4-Pan Forced-Air Cold Drop-in
FC-4C-05120-FA	5-Pan Forced-Air Cold Drop-in
FC-4C-03120-FAFF	3-Pan Forced-Air Cold Drop-in, Flat Flange
FC-4C-04120-FAFF	4-Pan Forced-Air Cold Drop-in, Flat Flange
FC-4C-05120-FAFF	5-Pan Forced-Air Cold Drop-in, Flat Flange

### FEATURES & BENEFITS

- Dual-forced air flows across two sides for even chilling.
- R513A refrigerant is non-flammable and has low-global-warming-potential (GWP).
- Remote on/off switch, with 4 ft. (1.2 m) cord, can be mounted to any cabinet side.
- Shallow recess has a more-prominent food display.
- Standard mounting clips are included for easy installation on counters up to 3" (7.6 cm) thick.
- Top is 18-gauge 300-series stainless steel, with a flat work surface around the opening and die-stamped, full-perimeter drip edge with a molded breaker gasket underneath.
- Seamless well is 18-gauge 300-series stainless steel.
- Exterior housing is 18-gauge galvanized steel.
- The inner well assembly is insulated with foamed-in-place polyurethane.
- Well accepts food pans up to 6" (15.2 cm) deep.
- Factory-set cold-control-on compressor provides mini-defrost with every compressor-off cycle.
- Condensing unit is suspended below well.
- ¾"(1.9 cm) integral drain is standard.
- 6 ft (1.5 m) cord with plug is included.
- Drip-free flange can be replaced with flat flange by adding "FF" to item number.
- Limit room relative humidity to 60% maximum to reduce cooling coil frost build-up.

Approvals	Date

# FORCED-AIR COLD-PAN DROP-INS

## DIMENSIONS — Shown in inches (cm)

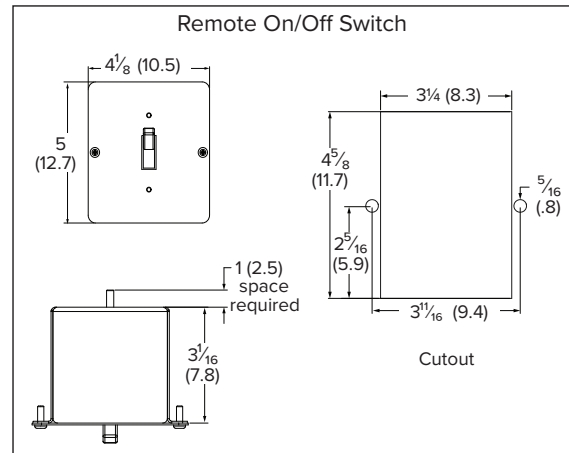
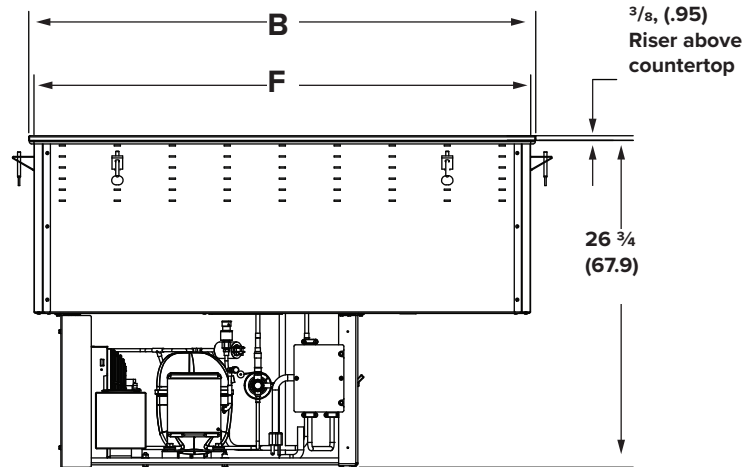

Operator Side View

## VENTING REQUIREMENTS

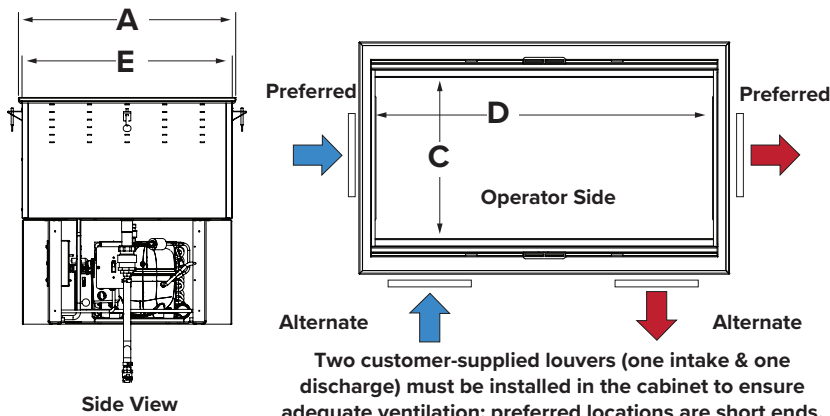

Side View

## PAN PLACEMENT

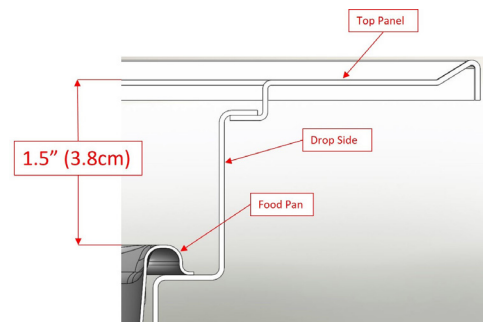

For proper distribution of cold air over the food, the tops of the food pans/containers must be at least 1.5" (3.8) below the top surface of the unit.

## SPECIFICATIONS

Item	Pans	Dimensions						Louvers	Weight LB (Kg)	Comp. (HP)	Peak Heat of Rej. (BTUH)	Refrig. Chg. oz	V	Hz	Amps	Plug & Receptacle
		Overall		Inner		Cutout										
		A	B	C	D	E	F									
FC-4C-03120-FA FC-4C03120-FAFF	3	26 (66)	41 1/2 (105.4)	19 5/16 (50.6)	37 7/8 (96.2)	25 1/4 (64.1)	40 3/4 (103.5)	8x10 (20.3x 25.4)	112 (50)	1/3	4800	9	120	60	7.1	NEMA 5-15P & 5-15R Straight Blade
FC-4C-04120-FA FC-4C-04120-FAFF	4		54 3/4 (170)		50 5/8 (128.6)		54 (137.2)									
FC-4C-05120-FA FC-4C-05120-FAFF	5		68 (172.7)		63 3/8 (161)		67 1/4 (170.8)		165 (74.8)							

**NOTICE:** Vollrath® Drop-Ins are made to order and cannot be returned. It is the responsibility of the installer to ensure cut-outs on new installations are correct, or retrofit installation dimensions match with Vollrath product dimensions. Vollrath will not guarantee that our models retrofit with specific competitive models (as competitive specifications can change without notice). We recommend countertop cut-outs be made after receipt of the Vollrath drop-in to ensure proper fit prior to cutting into countertop materials.

**NOTICE:** Do NOT modify the cord or plug. Modification may damage the drop-in or cause injury, and will void the warranty.



The Vollrath Company, L.L.C.  
1236 North 18th Street  
Sheboygan, WI 53081-3201 U.S.A.  
Main Tel: 800.624.2051 or 920.457.4851  
Main Fax: 800.752.5620 or 920.459.6573  
Customer Service: 800.628.0830  
Canada Customer Service: 800.695.8560

**Technical Services**  
techservicereps@vollrathco.com  
Induction: 800.825.6036  
Countertop Warming: 800.354.1970  
Other Products: 800.628.0832