



*Model CompanionCart-2  
Operator's Manual  
513722 Rev.1*

# Section 1: Introduction

INTRODUCTION

OPERATION

This manual provides basic information about the cart. Instructions and suggestions are given covering its operation and care.

The illustrations and specifications are not binding in detail. We reserve the right to make changes to the cart without notice, and without incurring any obligation to modify or provide new parts for carts built prior to date of change.

DO NOT ATTEMPT to operate the cart until instructions and safety precautions in this manual are read completely and are thoroughly understood. If problems develop or questions arise in connection with installation, operation, or servicing of the cart, contact Stoelting.

MAINTENANCE

TROUBLESHOOTING

PARTS



[stoeltingfoodservice.com](http://stoeltingfoodservice.com)

Stoelting Foodservice Equipment  
502 Highway 67  
Kiel, WI 53042-1600  
U.S.A.

White Glove Service Network  
Phone: 888.319.9549

© 2019 Stoelting

# Section 1: Introduction

This manual is divided into the following five sections:

## INTRODUCTION

- A. Parts of the Cart
- B. Specifications
- C. Assembly

## OPERATION

- A. Setup Cart
- B. Cleaning Process
- C. Drain Cart

## MAINTENANCE

- A. Testing with pH Test Strips
- B. Sanitizing Fresh Water Tank and Pump
- C. Clean Gray Water Tank
- D. Battery Replacement

## TROUBLESHOOTING

- A. Troubleshooting Table

## PARTS

- A. CompanionCart Replacement Parts

INTRODUCTION

OPERATION

MAINTENANCE

TROUBLESHOOTING

PARTS

# Section 1: Introduction

INTRODUCTION

OPERATION

MAINTENANCE

TROUBLESHOOTING

PARTS

## A. Parts of the Cart

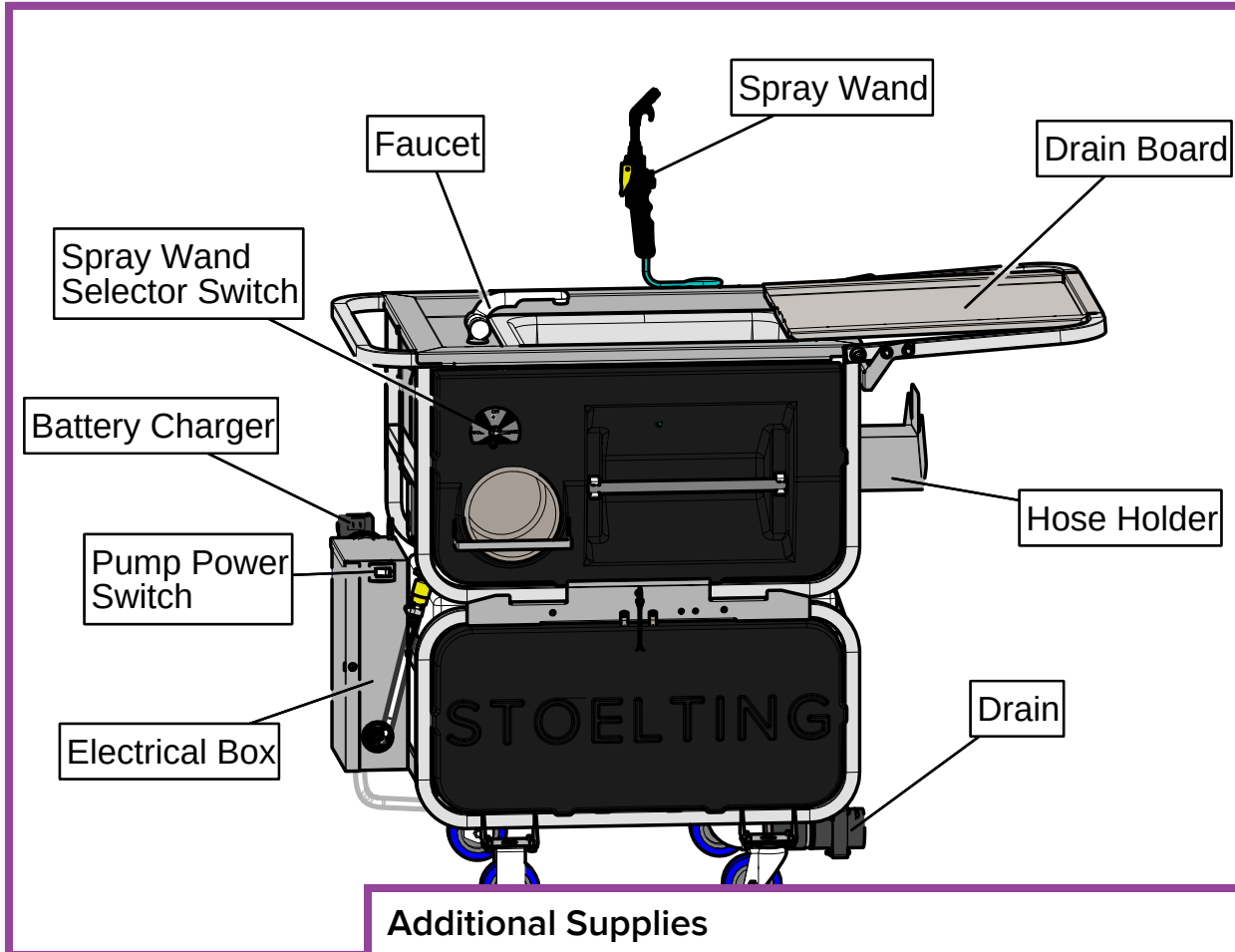

### Additional Supplies

Part 265003  
1 gallon Sanitizer  
Concentrate



Part 558203  
Standard Paper  
Towel Roll

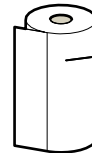

Part 265002  
Cleaning Wipes



Part 552002  
2.5 gallon  
Pail with Handle

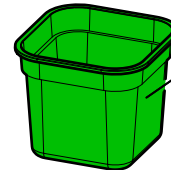

## B. Specifications

Model CIPCART-2	
<b>Dimensions</b> width height depth	<b>Cart</b>
	52-7/8" (134,3 cm)
	42" (106,7 cm)
<b>Weight (dry)</b>	180 lbs (81,6 kg)
<b>Fresh Water Tank</b>	15 gallon (56.78 liters)
<b>Gray Water Tank</b>	15 gallon (56.78 liters)
<b>Gray Water Tank Outlet</b>	2" N.P.T.

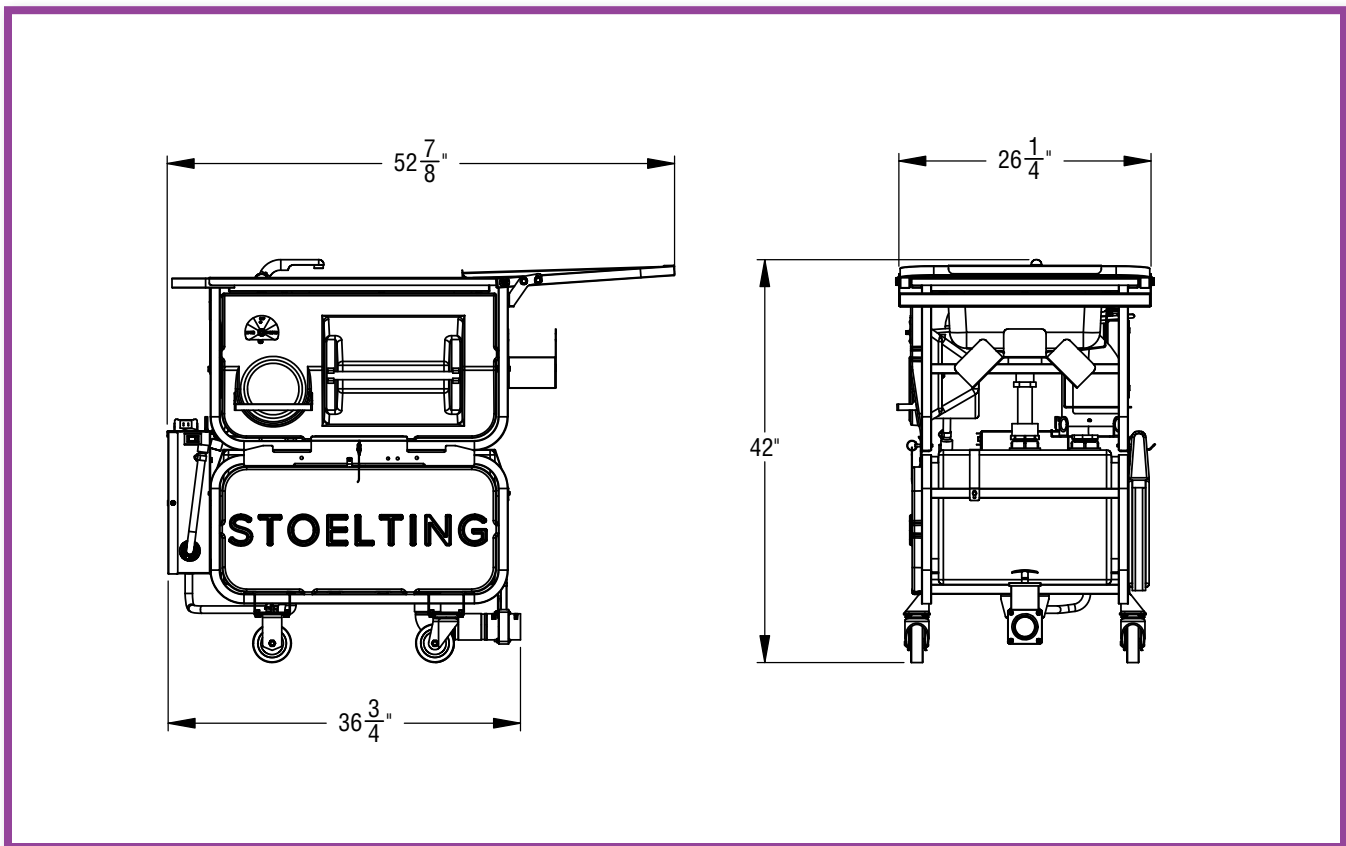

# Section 1: Introduction

INTRODUCTION

OPERATION

MAINTENANCE

TROUBLESHOOTING

PARTS

## C. Assembly

### C.1

The upper and lower sections of the cart are shipped separately. Unbox both sections and remove all packing materials.

### C.2

The hose holder bracket and the stool bracket are installed for compact shipping.

The brackets need to be repositioned to face outwards.

Unscrew the nuts holding the brackets to the frame, move the brackets, and tighten the nuts.

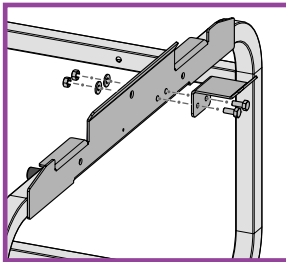
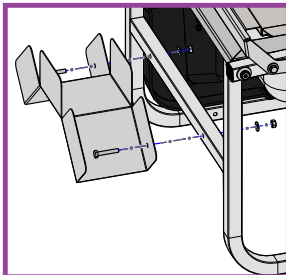

### C.3

Place the lower section on a flat surface.

### C.4

Place the upper section onto the lower section making sure the sink's drain pipe aligns with the gray water tank opening.

Secure the sections together using the two attached pins.

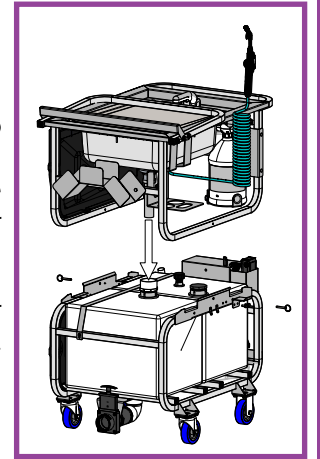

### C.5

Connect the fresh water hose from the pump to the faucet at the threaded fitting. Tighten by hand.

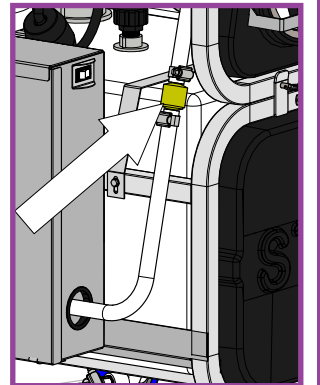

### C.6

Connect the 1 gallon container of sanitizing concentrate (not included) to the mixing valve.

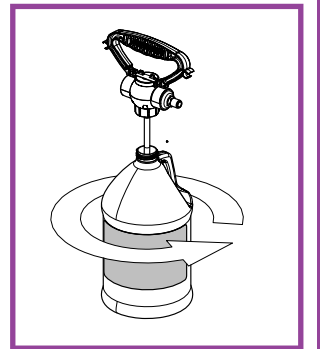

## C.7

Install the container into the bracket.

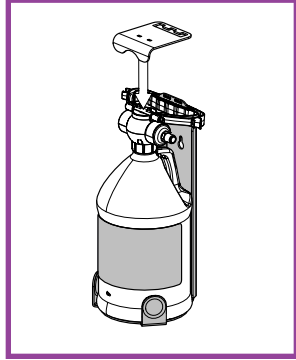

## C.8

Install the cleaning wipes and paper towels (not included).

## C.9

Connect the battery.

1. Remove the battery compartment screws to access the battery.
2. Connect the spade terminals to the battery.
3. Install the compartment cover.

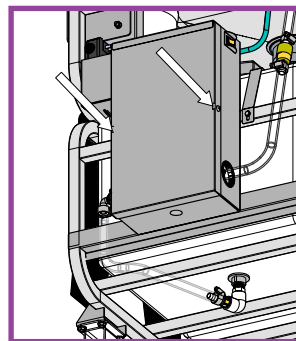

## C.10

Charge the pump battery.

1. Connect the charger wire to the plug exiting the electrical box.
2. Plug the charger into a wall outlet.

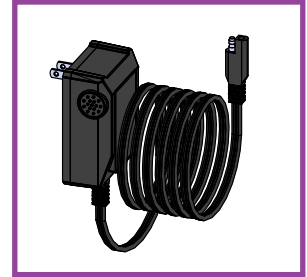

## C.11

The charger has green and red status LEDs.

Green LED Flashing: battery is 80% charged

Green LED Steady: battery is fully charged and can be disconnected. It may also stay connected to maintain the battery indefinitely.

Red LED Flashing: battery voltage is too low or there is not a good connection to the charger. Reconnect the charging cables or replace the battery if the red LED continues to flash.

Red LED Steady: battery is charging properly.

### NOTE

Make sure to disconnect the charger from the power source prior to turning on the pump.

### NOTE

Prior to the first use, the fresh water tank and pump must be sanitized. Refer to the Maintenance Section for details.

# Section 2: Operation

INTRODUCTION

OPERATION

MAINTENANCE

TROUBLESHOOTING

PARTS

## A. Prepare Cart

### A.1

Remove the 2" plug from the fresh water tank and set aside.

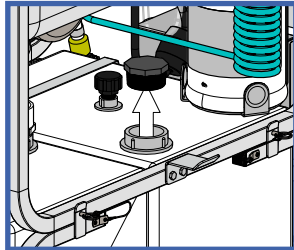

### A.2

Connect the 50' hose to the water source and fill the fresh water tank with 115°F to 120°F potable water. Then install the 2" plug into the fresh water tank.

The water must be used while it is still hot in order for the cleaning process to be effective.

### NOTE

Do not store or transport cart in freezing temperatures with water in the tanks or hoses.

### A.3

Wheel the cart into place by the machine.

### A.4

Open the drain board support and slide the drain board onto the support.

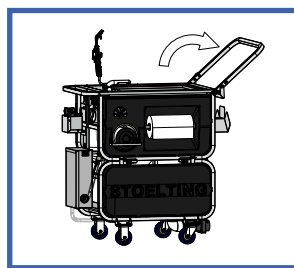

## B. Cleaning Process

### B.1

Turn the pump on.

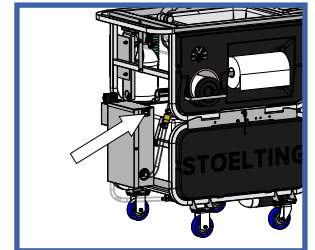

### B.2

Drain the hopper(s) and freezing cylinder(s) into a bucket. Rinse them using the spray wand. Set the selector switch to "Water" when rinsing.

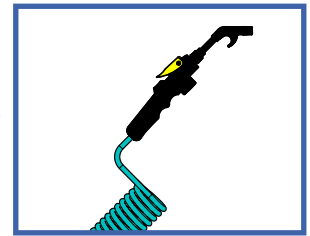

The drained product can be discarded directly into the sink.

### NOTE

The gray water tank holds a maximum of 15 gallons of liquid. Note the amount of mix poured into the sink so as not to overfill the gray water tank.



## B.3

Disassemble the parts in the freezing cylinder(s) and rinse them in the sink using the faucet and the spray wand

## B.4

Clean the drain board with a cleaning wipe.

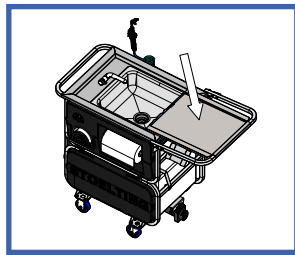

## B.5

Plug the sink with the sink strainer and fill it with water. Add a mild detergent per manufacturer's instructions.

## B.6

Thoroughly wash all parts then place them on the drain board.

## B.7

Drain the sink and fill with water for rinsing. Place the parts in the sink to remove any remaining washing solution.

## B.8

Drain the sink and fill with sanitizing solution. Do one of the following:

1. Use Stera-Sheen or equivalent. Follow the sanitizer manufacturer's instructions for preparing the sanitizing solution.
2. Use the spray wand to fill the sink. Make sure the selector switch is set to the "Mixed" position.

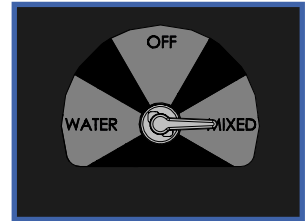

## B.9

While parts are in the sanitizing solution, wash and sanitize the drain board, machine hopper, and barrel(s).

## B.10

After 5 minutes in the sanitizing solution, remove all parts and let them air dry on the drain board.

## B.11

Drain the sink.

# Section 2: Operation

INTRODUCTION

## B.12

Assemble the machine and make at least 2 gallons of sanitizing solution for each freezing cylinder.

To make the sanitizing solution do one of the following:

1. Set the selector switch on the cart to “Mixed” and use the spray wand
2. Use the faucet and add Stera Sheen

OPERATION

## B.13

Sanitize the machine then empty the used sanitizing solution into the sink drain.

MAINTENANCE

### NOTE

The gray water tank holds a maximum of 15 gallons of liquid. The tank may be nearly full if a large amount of mix was drained when emptying the machine. To prevent spillage, do not overfill the gray water tank.

TROUBLESHOOTING

## B.15

Turn the pump off.

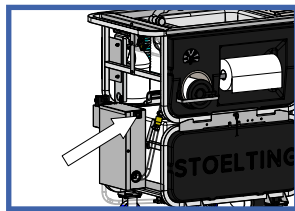

PARTS

The machine is now ready to make product. Add mix and start the machine per the machine instructions.

## C. Drain Cart

### NOTE

Do not store or transport the cart in below freezing temperatures with water in the tanks or hoses.

## C.1

Position cart so the gray water outlet is over a floor drain and connect the 2” elbow to the drain fitting if desired.

## C.3

Pull the drain gate upwards to drain the gray water.

Turn the pump on and open the faucet until the fresh water tank is empty. Then turn the pump off and close the drain gate.

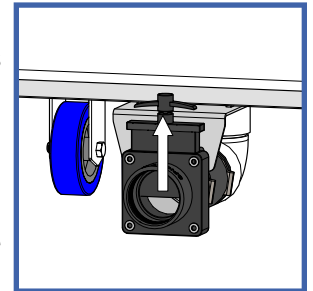

### NOTE

To prevent splashing, do not fully open the gate when the tank is full.

## C.4

Connect the battery charger to a power source until the next use. The battery charger automatically maintains proper battery charge. Battery life will be increased if it is stored while connected to the charger.

## A. Testing with pH Test Strips

Periodically test the spray wand using the pH Test Strips.

### A.1

Dispense about 8 oz. of sanitizer solution into a clean container using the spray wand.

### A.2

Remove a 2" length from the pH Test Strip roll and dip it into the sanitizer solution.

### A.3

Remove the Test Strip from the liquid and compare it to the color chart on the packaging.

A pH reading of 3.5 or less is a good reading.

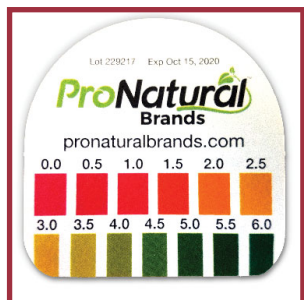

### A.4

If the pH is greater than 3.5, contact Stoelting White Glove Service to order a replacement spray wand.

## B. Sanitizing Fresh Water Tank and Pump

Prior to the first use, the fresh water tank and pump must be sanitized.

### B.1

Fill the fresh water tank with 15 gallons of sanitizing solution. Mix sanitizer according to manufacturer's instructions to provide a 100 parts per million strength solution.

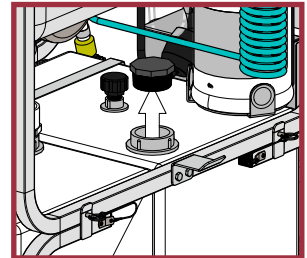

# Section 3: Maintenance

INTRODUCTION

## B.2

Turn on the pump.

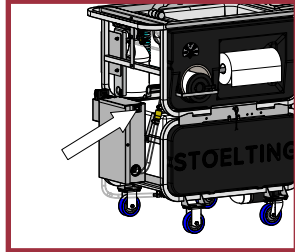

OPERATION

## B.3

Open the faucet and allow all of the solution to flow through the pump.

MAINTENANCE

## B.4

Once drained, close the faucet and turn the pump off and drain the gray water tank:

1. Position cart so the gray water outlet is over a floor drain.
2. Connect the 2" elbow to the drain fitting if desired.
3. Pull the drain gate upwards to drain the gray water. Note: To prevent splashing, do not fully open the gate when the tank is full.

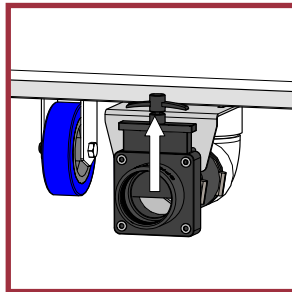

TROUBLESHOOTING

PARTS

## C. Clean Gray Water Tank

### C.1

The gray water tank must be cleaned regularly. Prior to cleaning, complete the following:

1. Empty the gray water tank
2. Fill the fresh water tank with at least 2 gallons of potable water
3. Charge the pump battery

### C.2

Disconnect the water line.

Disconnect the upper section of the cart by pulling out the two pins and remove the upper section.

Set the upper section down close enough to reconnect the water line.

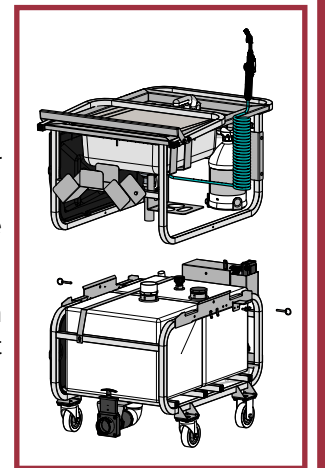

### C.3

Reconnect the water line then turn the pump on.

## C.4

Use the spray wand to thoroughly wash the inside surface of the gray water tank.

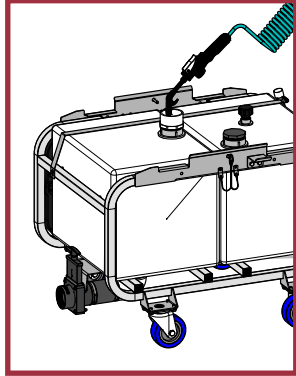

## C.5

Turn the pump off.

Place the upper section of the cart onto the lower section and secure it with the two pins.

Connect the water line.

## C.7

Drain the gray water tank:

1. Position cart so the gray water outlet is over a floor drain.
2. Connect the 2" elbow to the drain fitting if desired.
3. Pull the drain gate upwards to drain the gray water.  
Note: To prevent splashing, do not fully open the gate when the tank is full.

## D. Battery Replacement

### D.1

Open the battery cover. The cover is secured by two screws located at the bottom of the compartment.

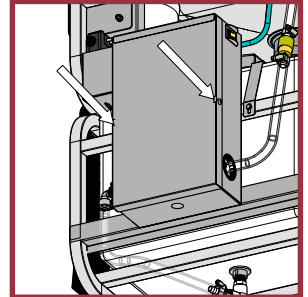

### D.2

Remove the stainless steel strap

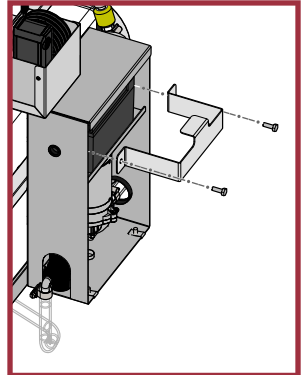

### D.3

Pull the spade connectors off the battery.

# Section 3: Maintenance

INTRODUCTION

## D.4

Remove the old battery and insert a new battery onto the shelf.

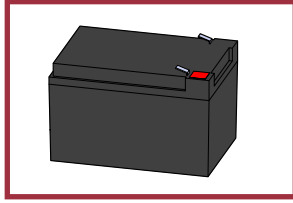

OPERATION

## D.5

Install the strap and connect the battery making sure to connect the positive connector (red wire) to the '+' and the negative connector (black wire) to the '-'.

MAINTENANCE

## D.6

Charge the new battery.

TROUBLESHOOTING

## D.7

Recycle or dispose of the old battery properly. Refer to local laws for proper disposal of sealed lead acid batteries.

PARTS

## E. Extended Storage

Do not store or transport the cart in below freezing temperatures with water in the tanks or hoses.

### E.1

Position cart so the gray water outlet is over a floor drain and connect the 2" elbow to the drain fitting if desired.

### E.2

Pull the drain gate upwards to drain the gray water.

Turn the pump on and open the faucet until the fresh water tank is empty then close the faucet.

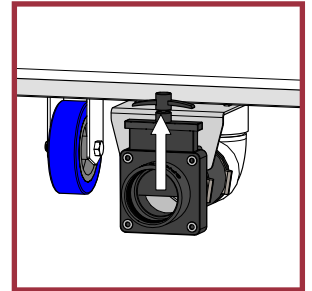

### E.5

Remove the sanitizing concentrate from the bracket and unscrew the mixing valve from the concentrate bottle.

Store the sanitizing concentrate in a location that remains above freezing.

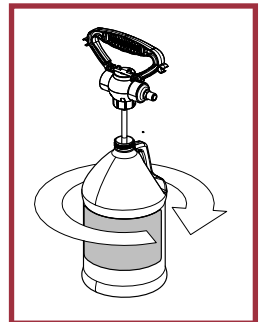

# Section 3: Maintenance

## E.3

Make sure the selector switch is set to the “Mixed” position.

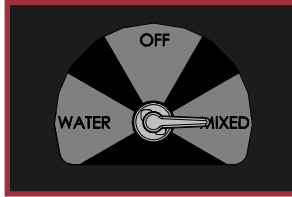

## E.4

When the fresh water tank is empty and the spray wand tubing is empty, turn off the pump and close the drain gate.

## E.4

Place the tubing of the mixing valve into a container with at least 8 oz clean water.

Flush the tubing using the spray wand until air comes out of the spray wand.

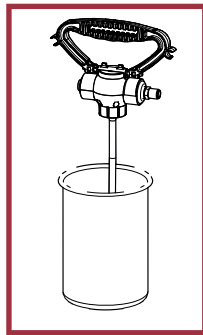

## E.6

Connect the battery charger to a power source.

If the cart is stored in a location without power, ensure the battery is fully charged then remove the negative terminal on the battery.

## E.3

Set the selector switch to the “Water” position and depress the lever on the spray wand until air comes out of the spray wand.

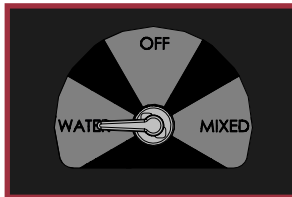

The cart is now ready to be stored for an extended period.

# Section 4: Troubleshooting

INTRODUCTION

Following are the most common issues with the CompanionCart. Refer to the following table before contacting Stoelting White Glove Service.

OPERATION

MAINTENANCE

TROUBLESHOOTING

PARTS

Problem	Possible Cause	Remedy
Pump not working	1. Battery not charged	1. Charge battery. Note: if the battery is fully discharged, it may take 12 hours to fully charge.
	2. Charger not connected properly	2. Disconnect the charger and reconnect it.
	3. Blown fuse	3. Replace the fuse.
	4. Bad battery	4. Replace the battery.
Battery charger shows red blinking status LED	1. Battery voltage is too low	1. Replace the battery.
	2. Charger not connected properly	2. Disconnect the charger and reconnect it.
Hoses are leaking	1. Loose hose connection	1. Check all hose connections and make sure they are installed correctly.



## A.1

### CompanionCart Replacement Parts

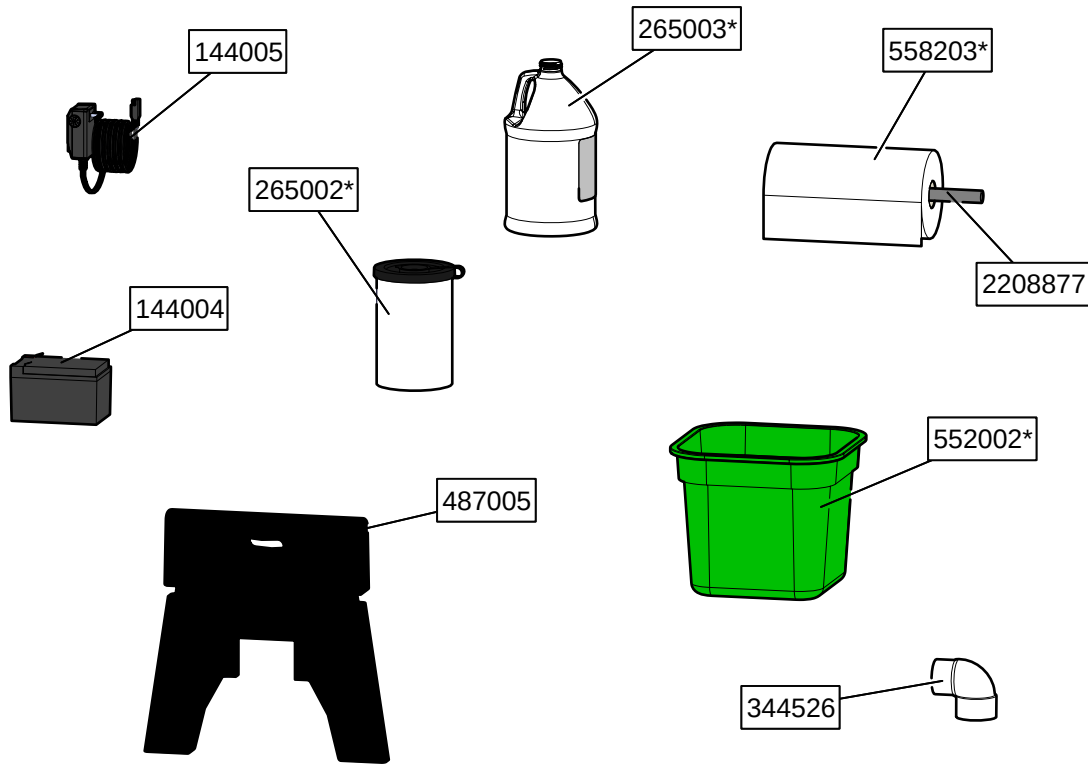

Part	Description	Quantity
144004	Battery - 12V 12Ah SLA	1
144005	Battery Charger - 12VDC	1
265002*	Cleaning Wipes	*
265003*	Liquid Sanitizer & Cleaner Concentrate - 1 gallon	*
344526	Drain Fitting - 2" 90°	1
487005	Stool - Collapsible	1
552002*	Pail - 2.5 Gallon w/Handle	*
558203*	Paper Towel Roll	*
2208877	Paper Towel Bar	1

\* Part does not ship with CompanionCart and can be purchased separately.





## COMPANIONCART WARRANTY

1. **Scope:**

Stoelting, A Vollrath Company ("Stoelting") warrants to the first user (the "Buyer") that the Stoelting-branded CompanionCart will be free from defects in materials and workmanship under normal use and proper maintenance for a period of one (1) year from the purchase date. This warranty is subject to all conditions, exceptions, and limitations contained herein.
2. **Disclaimer of Other Warranties:**

**THIS WARRANTY IS EXCLUSIVE; AND STOELTING HEREBY DISCLAIMS ANY IMPLIED WARRANTY OF MERCHANTABILITY OR FITNESS FOR PARTICULAR PURPOSE.**
3. **Remedies:**

Stoelting's sole obligations, and Buyer's sole remedies, for any breach of this warranty shall be, at Stoelting's option, one of the following: repair or replacement of the affected component at Stoelting's plant in Kiel, Wisconsin, or refund of the purchase price of the affected component. These obligations/remedies are subject to the conditions that Buyer (a) gives Stoelting prompt written notice of any claimed breach of warranty within the applicable warranty period, and (b) delivers the affected component to Stoelting or its designated service location, in its original packaging/crating, also within that period. Buyer shall bear the cost and risk of shipping to and from Stoelting's plant or designated service location.
4. **Conditions:**
  - a) Stoelting shall not be responsible to provide any remedy under this warranty with respect to any component that fails by reason of negligence, abnormal use, misuse or abuse, faulty repair made by others, use with parts or equipment not manufactured or supplied by Stoelting, any modification or alteration of any parts or equipment, or damage in transit.
  - b) The Authorized Stoelting Provider must return defective parts, at Stoelting's discretion, for credit.
5. **Exceptions:**

This warranty does **NOT** cover any of the following

  - a) Costs associated with installation labor, disposal of equipment being replaced, and shipping costs of replacement parts or CompanionCart.
  - b) This warranty does not extend to parts, sometimes called "wear parts", which are generally expected to deteriorate and to require replacement as the CompanionCart is used, including but limited to o-rings and batteries. All such parts are sold AS IS.
  - c) External components including but not limited to hoses, piping, or electrical equipment.
  - d) Labor and travel charges.
  - e) Failure, damage, or repairs due to faulty installation, misapplication, abuse, lack of service, or improper service, unauthorized alteration, improper operation as indicated in the Stoelting operators manual, including but not limited to failure to properly assemble and/or clean, improper tool usage, or use of unapproved lubrication, or cleaning and sanitizing supplies.
  - f) Any costs associated with electricity, including utility increases, from any reason whatsoever.
  - g) Any special, indirect or consequential property or commercial damage of any nature whatsoever, if the jurisdiction allows this exclusion.
7. **Limitations:**

**THE REMEDIES SET FORTH IN THIS WARRANTY SHALL BE THE SOLE LIABILITY STOELTING AND THE EXCLUSIVE REMEDY OF BUYER WITH RESPECT TO EQUIPMENT SUPPLIED BY STOELTING; AND IN NO EVENT SHALL STOELTING BE LIABLE FOR ANY INCIDENTAL OR CONSEQUENTIAL DAMAGES, INCLUDING AS EXAMPLES BUT NOT INTENDED TO BE LIMITED TO DOWNTIME, OVERHEAD, MATERIALS, PERFORMANCE PENALTIES, LOST SALES, LOST PROFITS, PRODUCT LOSS, OR PROPERTY DAMAGES, WHETHER FOR BREACH OF WARRANTY OR OTHER CONTRACT BREACH, NEGLIGENCE OR OTHER TORT, OR ON ANY STRICT LIABILITY THEORY.**

