



Outperform every day.™

Project:

Item Number:

Quantity:

HEAVY-DUTY SLICERS



40903 / 40904



40906

Heavy-Duty Slicers

DESCRIPTION

Vollrath's five heavy-duty slicers, all with 12" (30.5 cm) blades and a non-stick coating, are designed to meet the challenges of any high-use operation.

FEATURES

- Exclusive non-stick coating makes for easy clean up after slicing products
- One-piece, light weight, hard-coated anodized aluminum body eliminates food traps
- Sand-molded, anodized aluminum base will never tarnish
- Clearance between the back of the blade and the motor provides access for easy and thorough cleaning
- Receiving tray features raised edges to contain juices which keeps the slicer and work area clean
- Solid aluminum adjustment knob is easy to clean
- Heavy-duty blade guides will not flex, creating straight slices every time
- Precision spacing cam for more accurate thickness cutting
- Built-in easy to use two stone sharpener makes blade sharpening simple and convenient
- Heavy-weight pusher feeds product into the blade for easier cuts and less user fatigue
- Easy-tilt product feeder mechanism makes it easy to clean safely without the product feeder dropping
- Low-friction carriage system provides outstanding smooth glide motion
- Thermal overload protection with manual reset automatically shuts off slicer to protect from electrical damage
- 5 ft. (1.5 m) cord with plug

Agency Listings



Certified to NSF/ANSI 8-2010

WARRANTY: All models shown come with Vollrath's standard warranty against defects in materials and workmanship. For full warranty details, please refer to the Vollrath Equipment and Smallwares Catalog.

MODELS

- 40903** SLR7012/N Belt Driven (US/Canada)
- 40904** SLR 7712/N Belt Driven with Safe Blade Removal System (US/Canada)
- 40905-QC** SLR7012/N Belt Driven (Quebec)
- 40906** SLR7512/N Gear-Driven (US/Canada)
- 40907** SLR7912/N Automatic Slicer with Safe Blade Removal (US/Canada)
- 40908** SLM0012/N Belt Driven with Maximum Clearance Receiving Tray and Safe Blade Removal (US/Canada)

FEATURES (CONTINUED)

Belt Driven

- Heavy-duty slice adjustment for precise and consistent slice thickness
- Centered blade and gauge plate ensure stability under the toughest conditions

Gear Driven

- Direct drive gear transmission provides the power and robustness for high-volume slicing of cheese and meat

Maximum Clearance Receiving Tray

- Special clear slice exit design provides unobstructed receiving tray area for easier slicing and cleaning
- Extended 1 1/4" (3.175 cm) maximum slice thickness for greater versatility

Automatic Carriage

- Automatic carriage slices approximately 40 slices per minute for maximum operational efficiency
- Intuitive setup includes simple main switch and variable speed control
- Can also be used manually

MODEL COMPARISON

Feature	40903	40904	40905-QC	40906	40907	40908
Non-Stick Coating	X	X	X	X	X	X
Accommodates Vegetable Chute	X	X	X	X	X	X
Accommodates Frozen Food Blade	X	X	X	X	X	X
Safe Blade Removal System	-	X	-	-	X	X
Gear Drive	-	-	-	X	-	-
Belt Drive	X	X	X	-	X	X
Kickstand	-	-	-	X	X	X
Max Clearance Receiving Tray	-	-	-	-	-	X
Automatic Cartridge	-	-	-	-	X	-

Approvals	Date

Due to continued product improvement, please consult www.vollrath.com for current product specifications.



Outperform every day.™
www.vollrath.com

The Vollrath Company, L.L.C.
1236 North 18th Street
Sheboygan, WI 53081-3201 U.S.A.
Customer Service: 800.628.0830
Canada Customer Service: 800.695.8560
Main Fax: 800.752.5620 or 920.459.6573

Technical Services: 800.628.0832
Technical Services Fax: 920.459.5462

HEAVY-DUTY SLICERS

MODELS

40903	SLR7012/N Belt Driven (US/Canada)	40906	SLR7512/N Gear-Driven (US/Canada)
40904	SLR 7712/N Belt Driven with Safe Blade Removal System (US/Canada)	40907	SLR7912/N Automatic Slicer with Safe Blade Removal (US/Canada)
40905-QC	SLR7012/N Belt Driven (Quebec)	40908	SLM0012/N Belt Driven with Maximum Clearance Receiving Tray and Safe Blade Removal (US/Canada)

DIMENSIONS

Dimensions shown in inches (cm).

40903 / 40904 / 40905-QC

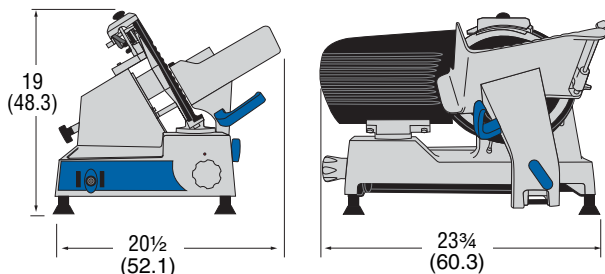

Front View

Side View

40906

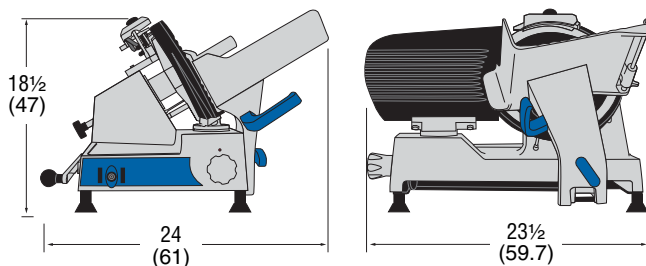

Front View

Side View

40907

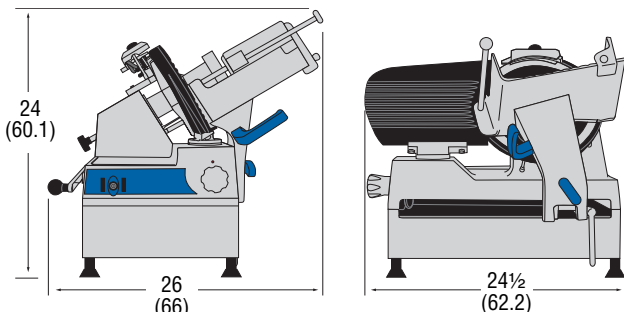

Front View

Side View

40908

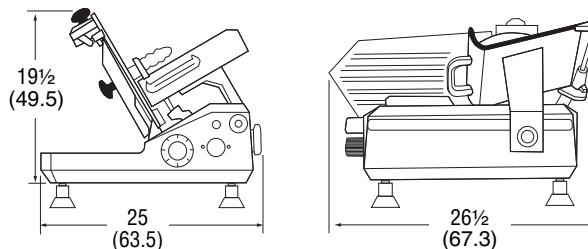

Front View

Side View

SPECIFICATIONS

Item	Drive	Slicing Capacity		HP	Voltage	Amps	Plug
		Processed Meats	Cheese				
40903	Belt	3 hr/day	1 hr /day or less	1/2	120	2.5	NEMA 5-15P
40904	Belt	3 hr/day	1 hr /day or less	1/2	120	2.5	NEMA 5-15P
40905-QC	Gear	3 hr/day	1 hr /day or less	1/2	120	2.5	NEMA 5-15P
40906	Gear	Continuous	Continuous	1/2	120	2.5	NEMA 5-15P
40907	Belt	Continuous	Continuous	3/4	120	4.7	NEMA 5-15P
40908	Belt	Continuous	3 hr/day	2/3	120	2.5	NEMA 5-15P

Receptacle

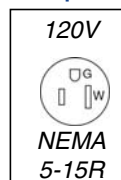

Outperform every day.™

www.vollrath.com

The Vollrath Company, L.L.C.
 1236 North 18th Street
 Sheboygan, WI 53081-3201 U.S.A.
 Customer Service: 800.628.0830
 Canada Customer Service: 800.695.8560
 Main Fax: 800.752.5620 or 920.459.6573

Technical Services: 800.628.0832
 Technical Services Fax: 920.459.5462